

# ATS-CVD Series Thermal CVD for Graphene Foam Synthesis



## Special Features

- ◆ Small scale of thermal CVD system for graphene foam synthesis
- ◆ Economical and efficient for graphene foam synthesis R&Ds
- ◆ 4" Quartz tube equipped
- ◆ One Heating zone
- ◆ High speed controlled in heating and cooling
- ◆ Easy process control

## Application

- ◆ Synthesis of graphene foam and other 2d /materials

## Specifications

- ◆ Dimension : 1,450W × 850D × 1510H (mm)
  - Furnace Body : approx. 500(D) x 520(H) x 450(W)
  - Quartz Tube : ID4inch x L1200
- ◆ Vacuum Furnace
  - Heating Element : Kanthal Wire (APM grade)
- ◆ Furnace Heater : One zone(max. temp.: 1100°C)
- ◆ Pump : Oil Rotary pump (400l/min)
- ◆ Gas : Ar, H<sub>2</sub>, CH<sub>4</sub>
- ◆ Electrical control : PLC-based PC control
- ◆ Utility spec.
  - Electrical : 220V, 3phase, 50A
  - Cooling water : 1~3kgf/cm<sup>2</sup>
  - Compressed air : 5~6kgf/cm<sup>2</sup>

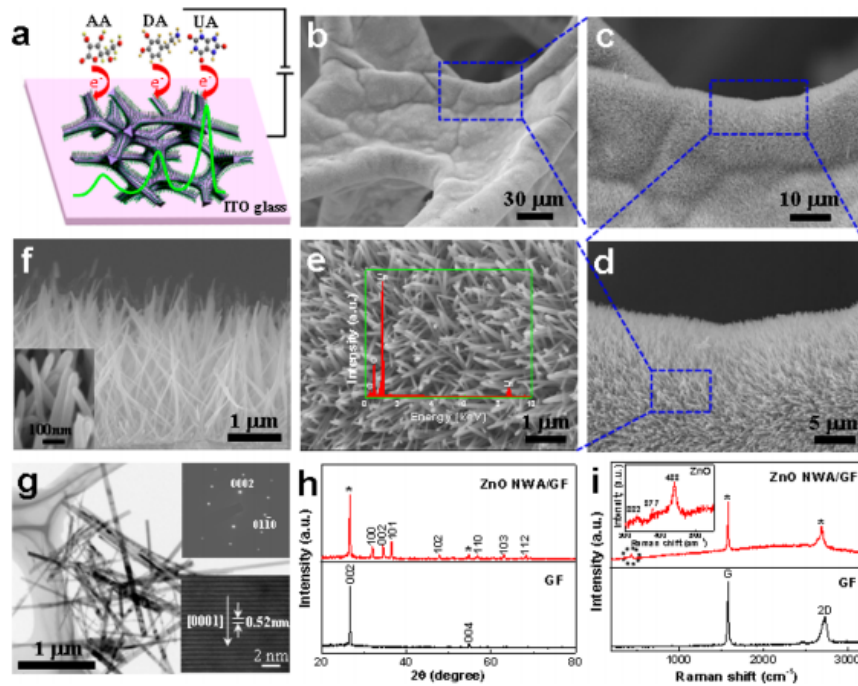

Figure 1. Structural analysis of the integrated ZnO NWA/GF. (a) Schematic of the ZnO NWA/GF electrode and detection of UA, DA, and AA. (b–e) SEM images of the ZnO NWAs on the 3D GF at different magnifications. Inset: EDX of the ZnO NWAs. (f) SEM images of the height of the ZnO NWAs,  $\sim 2 \mu\text{m}$ . Inset: diameter of the ZnO NWAs,  $\sim 40 \text{ nm}$ . (g) TEM images of the ZnO nanowires which were detached from GF by sonication and transferred on the TEM grid. Inset: SAED pattern (top) and HRTEM image of the ZnO nanowire (bottom). (h) XRD patterns and (i) Raman spectra of the GF and ZnO NWA/GF. Inset: magnification of the ZnO NWAs spectrum; \* indicates the peaks of the GF.

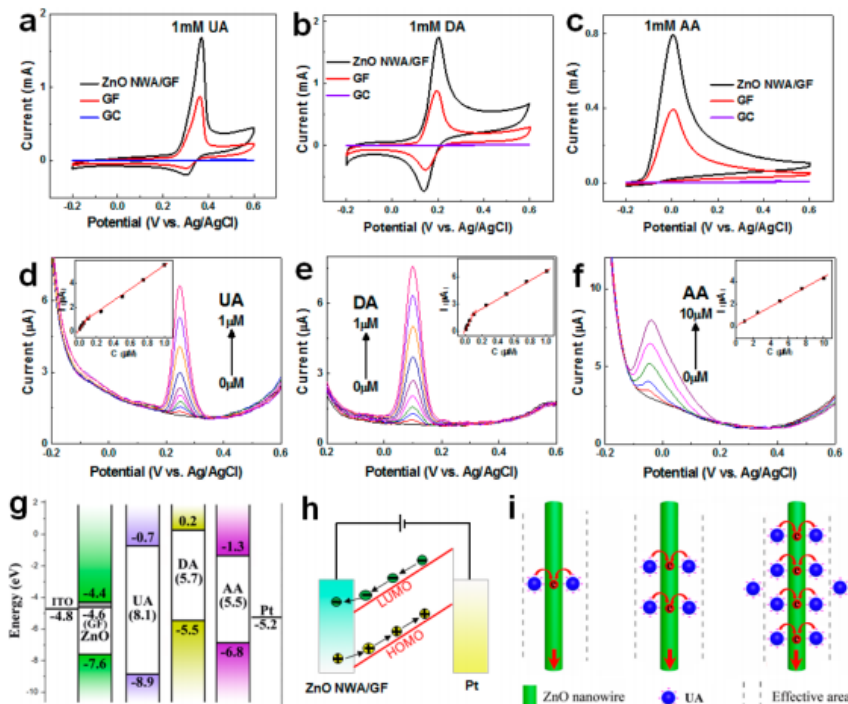

Figure 2. Electrochemical detection of UA, DA, and AA. (a–c) CV curves of the ZnO NWA/GF, GF, and bare GC electrodes in 1 mM UA, DA, and AA, respectively, at a scan rate of  $50 \text{ mV s}^{-1}$ . (d–f) DPV curves for UA, DA, and AA at different concentrations using a ZnO NWA/GF electrode. The UA concentrations from the bottom are 0, 0.001, 0.01, 0.025, 0.05, 0.1, 0.25, 0.5, 0.75, and  $1 \mu\text{M}$ . The DA concentrations from the bottom are 0, 0.001, 0.01, 0.025, 0.05, 0.1, 0.25, 0.5, 0.75, and  $1 \mu\text{M}$ . The AA concentrations from the bottom are 0, 1, 2.5, 5, 7.5, and  $10 \mu\text{M}$ . Insets: plots of the oxidation peak current vs concentration of each biomolecule, showing two slopes for UA and DA. (g) Flat band model (LUMO and HOMO) of the ZnO NWA/GF, UA, DA, and AA, and work function for the GF, ITO, and Pt electrodes. (h) Electron and hole transfer during oxidation of the biomolecules. (i) Schematic of the adsorbed biomolecule (UA) at different concentrations. The supporting electrolyte is a 0.1 M PBS solution (pH 7.4). DPV conditions: a pulse height of 50 mV, a step height of 4 mV, a pulse width of 0.2 s, a step time of 0.5 s, and a scan rate of  $8 \text{ mV s}^{-1}$ .

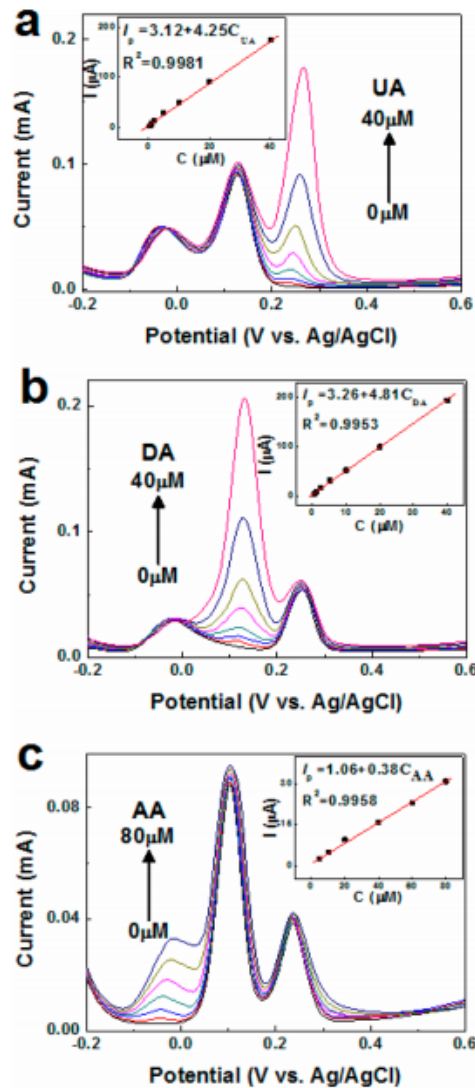

Figure 3. DPV measurements for mixed UA, DA, and AA. DPV curves for the ZnO NWA/GF electrode at varying concentrations of (a) UA in a mixture of 100 μM AA and 15 μM DA; the UA concentrations from the bottom are 0, 0.5, 1, 2.5, 5, 10, 20, and 40 μM; (b) DA in a mixture of 50 μM AA and 10 μM UA; the DA concentrations from the bottom are 0, 0.5, 1, 2.5, 5, 10, 20, and 40 μM; (c) AA in a mixture of 15 μM DA and 7.5 μM UA; AA concentrations from the bottom are 0, 5, 10, 20, 40, 60, and 80 μM. Insets: plots of the oxidation peak current vs the concentration of each biomolecule. The supporting electrolyte and the DPV conditions are the same as in Figure 2.

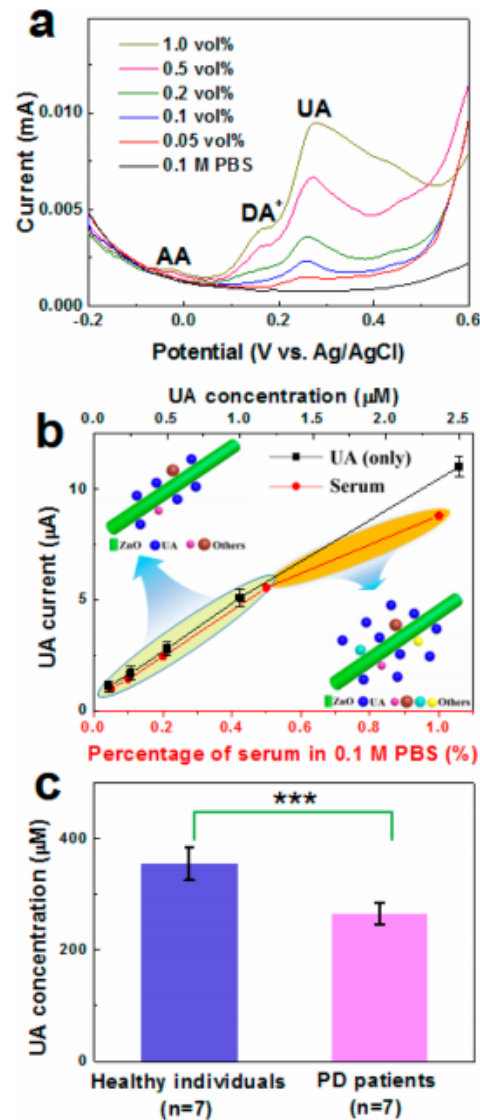

Figure 4. DPV measurements in serum of patients from Parkinson's disease (PD). (a) DPV curves of different volume fractions of PD serum in a 0.1 M PBS solution (pH 7.4) for a ZnO NWA/GF electrode. (b) Relationship between the UA peak current and the percentage of serum in a 0.1 M PBS solution (the calibration curve is shown in black). The error bars represent the standard deviation obtained from four measurements. (c) Statistical analysis of healthy individuals and PD patients serum UA levels in a 0.1 M PBS solution. The average serum UA levels were  $355 \pm 30 \mu\text{M}$  in the healthy individuals ( $n = 7$ ) and  $265 \pm 20 \mu\text{M}$  in the PD patients ( $n = 7$ ), respectively. Inset: asterisks denoted data points representing an experimental group significantly different statistically ( $***p < 0.001$ ) from healthy control group. The DPV conditions are the same as in Figure 2.

## ZnO Nanowire Arrays on 3D Hierarchical Graphene Foam: Biomarker Detection of Parkinson's Disease

Hong Yan Yue,<sup>1,2,5,\*</sup> Shuo Huang,<sup>1,2,\*</sup> Jian Chang,<sup>1,2</sup> Chaejeong Heo,<sup>3</sup> Fei Yao,<sup>1,2</sup> Subash Adhikari,<sup>1,2</sup> Fethullah Gunes,<sup>2</sup> Li Chun Liu,<sup>2</sup> Tae Hoon Lee,<sup>2,4</sup> Eung Seok Oh,<sup>1</sup> Bing Li,<sup>1,2</sup> Jian Jiao Zhang,<sup>5</sup> Ta Quang Huy,<sup>1,2</sup> Nguyen Van Luan,<sup>1,2</sup> and Young Hee Lee<sup>1,2,\*</sup>



## Pumping Control Interface

**Pumping Control**

**Gas Control**

- H2 (100 sccm)
- CH4 (200 sccm)
- Ar (1,000 sccm)

**Furnace**

- Vacuum Gauge: LOW
- Heater Indicator: SV 11.25, PV 11.25, Out 0%
- Current: 0 A, Voltage: 0 V
- Rotary Pump

**APC Controller**

- Baratron: 1.197 Torr
- Position: 100%
- Gain: 100, 500, 100, 150
- Lead: 1.85, 1.85, 1.85, 1.85

**Communication**

- PLC
- Heater Controller
- Vacuum Controller
- APC Controller
- V.A Meter

**Step Setting**

- Time: 0 min
- Heater: 0
- H2(100sccm): 0 sccm
- CH4(200sccm): 0 sccm
- Ar(1,000sccm): 0 sccm
- Baratron: Open

**Recipe Table**

NO	Time(min)	Heater	H2 (100sccm)	CH4(200sccm)	Ar(1,000sccm)	Baratron
1	5	5	0	100	0	Open

**Process Start**

Step Status: Ready, Process Time: 00:00:00

## DAQ Interface

**DAQ**

**Graph**

Heater Voltage (Left Y-axis), Gas Current (Right Y-axis) vs Time (min) (X-axis)

**Data Table**

Time(m)	Value
Heater	
H2	
CH4	
Ar	
Baratron	
Heater SV	
Current	
Voltage	

**Step Setting**

- Time: 0 min
- Heater: 0
- H2(100sccm): 0 sccm
- CH4(200sccm): 0 sccm
- Ar(1,000sccm): 0 sccm
- Baratron: Open

**Recipe Table**

NO	Time(min)	Heater	H2 (100sccm)	CH4(200sccm)	Ar(1,000sccm)	Baratron
1	5	5	0	100	0	Open

**Process Start**

Step Status: Ready, Process Time: 00:00:00

Layout

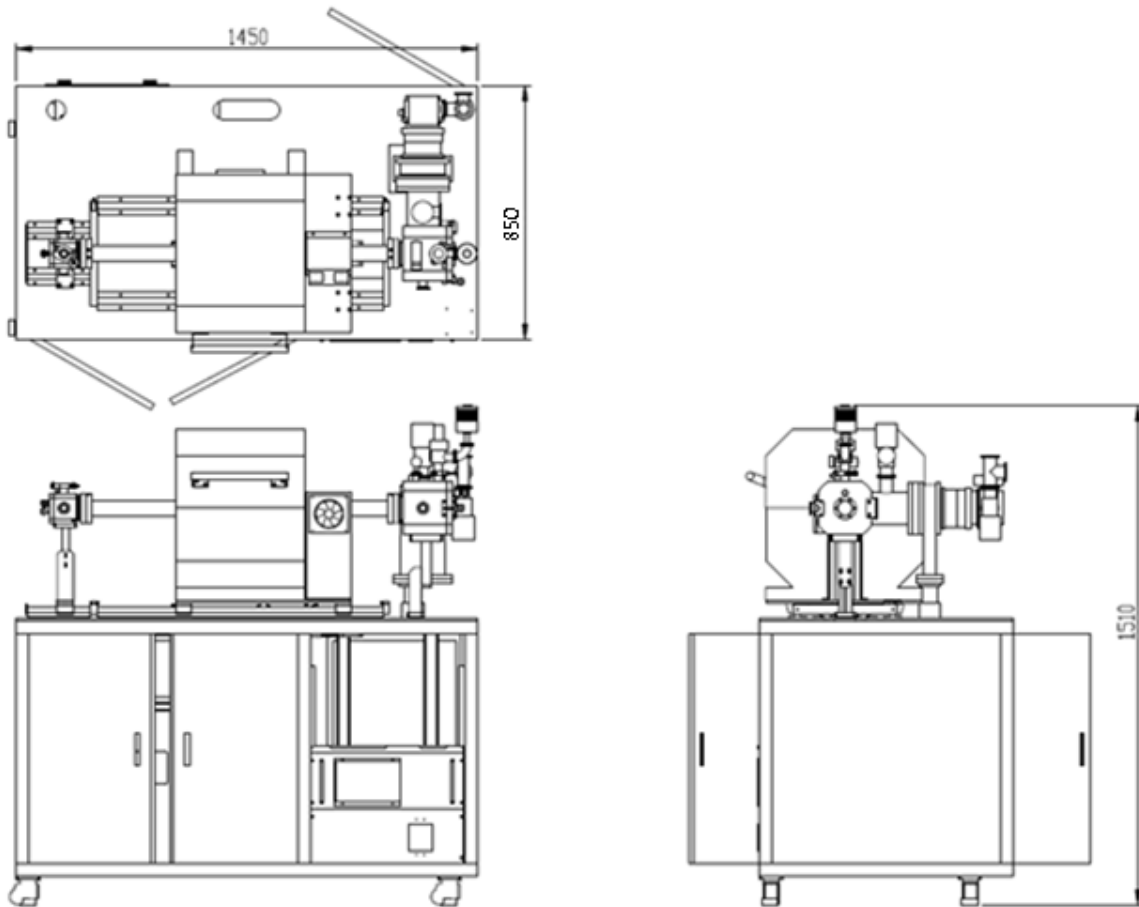

175-25, Cheongcheon-Dong 2, Bupyeong-Gu,  
Incheon, 403-853, Rep. Korea  
Phone: +82-32-508-8060/8067  
Fax: +82-32-508-8069  
E-mail: [atech@atechsystem.co.kr](mailto:atech@atechsystem.co.kr)  
Website: [www.atechsystem.co.kr](http://www.atechsystem.co.kr)